

## Suction Lines And Skimmers For Petrochemical Tanks

BTE custom design suction lines and skimmers to suit a variety of applications. Our experience indicates that suction lines often need special engineering design to suit individual requirements. BTE engineers have a wide variety of designs to draw upon. Some of these are shown on this leaflet. Suction lines can consist of a single pipe with one swing joint, or 2 pipes and multiple swing joints if a single pipe will not give sufficient working height. BTE engineers designed the now operating 9 x 24" Hong Kong Airport and 8 x 20" Kuala Lumpur Airport floating suction lines.

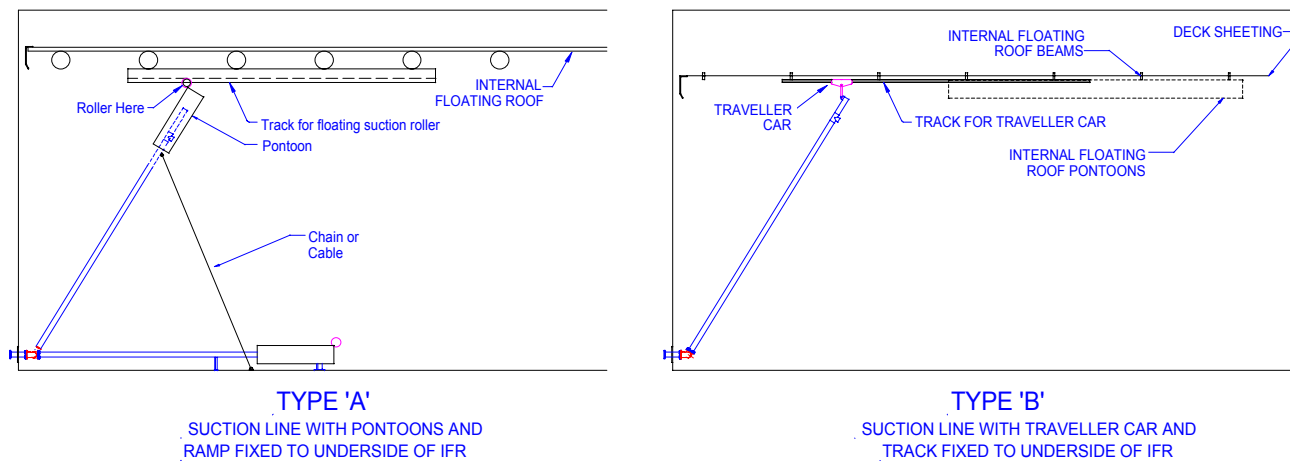

### SUCTION LINES FOR USE WITH ALUMINIUM INTERNAL FLOATING ROOFS (IFRs):

**Type A:** This is the most common type, consisting of a ramp attached to the IFR underside. Additional flotation must be added to the IFR to compensate for the extra weight of the ramp. Additionally, suction line pontoon calculations must consider the buoyant up-thrust when water or products having a high and variable S.G. (such as Sulfolane) are stored in the tank. Too much buoyant up-thrust may damage the IFR. BTE engineers have engineered solutions to overcome these design problems.

**Type B:** This type of line involves attaching a track with traveller car to the IFR underside. It offers advantages over using pontoons to lift the suction line;

- No buoyancy up-thrust problem to consider.
- Floor can be free of supports, as line is always suspended by IFR.
- No possibility of suction line pontoons leaking.
- This design has been in trouble free service for over 10 years.

**Size Range:** 3 inch to 36 inch diameter.

**Materials:** Suction lines can be made in stainless steel, carbon steel, or aluminium.

**Finish :** Carbon steel lines can be epoxy painted to customer specification

**Jet A1:** These lines are most commonly supplied in stainless steel.



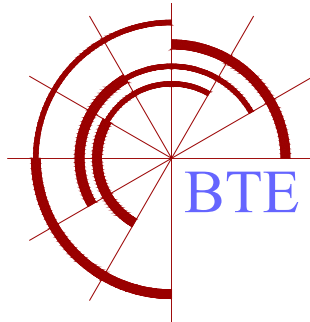

## Suction Lines And Skimmers For Petrochemical Tanks

### Level Indicator

A BTE Level Indicator can be fitted to any kind of single arm suction line with or without floating roof

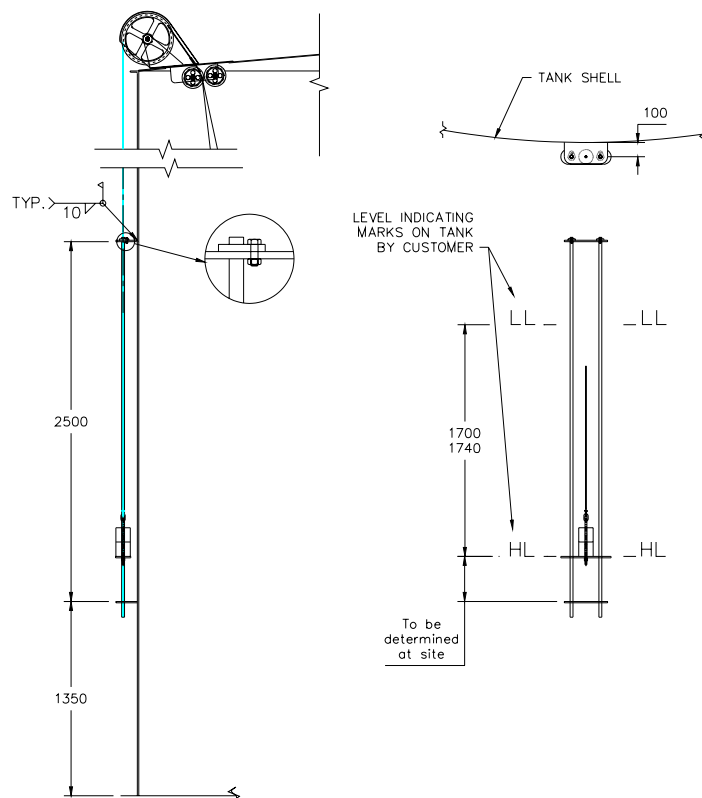

### Tall Tanks

Type 'C' Articulated suction lines or skimmers can be used where the tank height is greater than the diameter

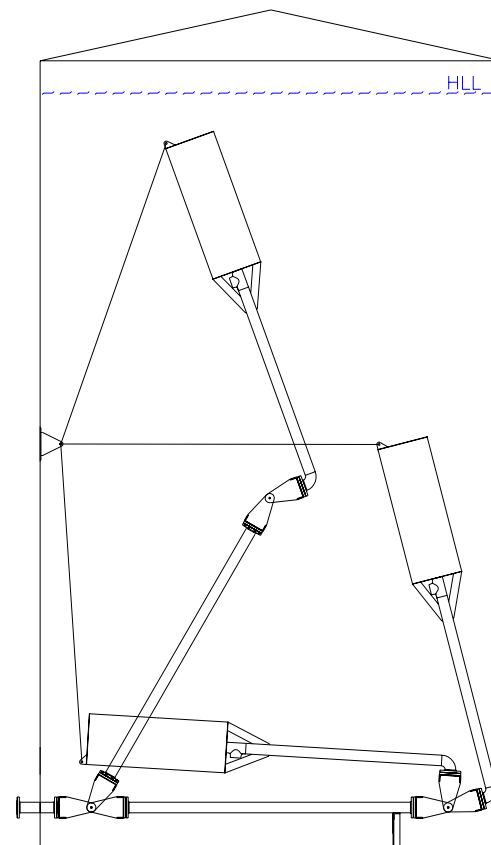

TYPE 'C', ARTICULATED,  
FOR TANKS HAVING A TALL ASPECT RATIO

### BTE Tank Products include:

- Aluminium Internal Floating Roofs
- Floating Roof Tank seals
- Floating Roof Tank Drain Systems
- Floating Roof Tank Fire Foam Systems
- Floating Suction lines & Skimmers
- Floating Suction Swing Joints 3" to 36"

Baillie Tank Equipment  
Sydney, Australia  
Tel: +61 2 9327 5481  
Fax: +61 2 9327 5488  
Sydney@BaillieTank.com

Baillie Tank Equipment  
Seoul, Korea  
Tel: +82 31 949 6854  
Fax: +82 31 949 6866  
Seoul@BaillieTank.com

Baillie Tank Equipment  
Beaumont TX, USA  
Tel: 409 722 6050  
Fax: 409 722 6144  
Beaumont@BaillieTank.com